

TOSHIBA MACHINE

TOSHIBA MACHINE'S
SCARA Robots TH Series

TH850A

- HIGH LOAD CAPACITY ·· Maximum 20kg
- HIGH SPEED ·· Cycle time 0.39s
(With 2kg payload)
- POSITIONING REPEATABILITY
·· X, Y ± 0.01 mm, Z ± 0.01 mm, C ± 0.004 deg
- HIGH RIGIDITY
- BUILT-IN PLC ·· Ready for Touch-Sensitive
Operation panel
- DUCT-LESS DESIGN

Robot specifications



Model	TH850A	
Type	Horizontal Multi-joint	
Number of controlled axis	4	
Arm length	850mm(350mm+500mm)	
Working envelope	Axis 1	$\pm 160^\circ$
	Axis 2	$\pm 145^\circ$
	Axis 3(Z-axis)	200mm(Option:400mm)
	Axis 4(Z-axis rotation)	$\pm 360^\circ$
Maximum speed	Axis 1	300°/s
	Axis 2	420°/s
	Axis 3(Z-axis)	2050mm/s
	Axis 4(Z-axis rotation)	1200°/s
	Composite	8.13m/s
Standard cycle time(with 2kg payload)*1	0.39s	
Maximum payload mass*2	20kg	
Allowable moment of inertia at end*2	0.2kgm ²	
Positioning repeatability*3	X-Y(Plane)	± 0.01 mm
	Z-axis (vertical)	± 0.01 mm
	Axis 4(Z-axis rotation)	$\pm 0.004^\circ$
Input/output signals for hand	5 inputs / 4 outputs	
Air piping for hand	$\phi 6 \times 4$ pcs.	
Position detecting system	Absolute system	
Robot-controller cable	5m (Optional length maximum 25m)	
Mass	76kg	

*1:Continuous operation of standard cycle motion pattern is not possible beyond the effective load ratio.
(Horizontal 300mm,vertical 25mm, round-trip, coarse positioning)
*2:Maximum speed rates and acceleration rates are limited depending on motion patterns, payload mass, and offset value.
*3:When the environment temperature is constant.

Controller specifications



Controller
TS3100

Model	TS3100	
No.of axis	No. of simultaneously controlled axes: 8 axes (2 additional axes under development)	
Operation mode	PTP,CP(Linear·Circular),Short-cut,Arch motion	
Storage capacity	Total: 12800 points + 25600 steps 1 program: 2000 points + 3000 steps	
No.of programs	Max.256(247 user files + 9 system files)	
Programming language	SCOL(proprietary,similar to BASIC)	
Teaching unit(option)	Teach pendant TP1000, with 5-meter cable (Program can be written on PC)	
External I/O	32 inputs/32 outputs	
Hand control signals	8 inputs/8 outputs	
External operation signal(exclusive)	Inputs:Program selection, start, stop, reset, etc Outputs:Servo-On status, emergency stop, ready for operation, malfunction alarm, etc	
Serial communication port	RS-232C: 2 ports, Ethernet: 1 port*4	
Other functions	Torque control,Interruptive functions, self-diagnosis, I/O control and communications during motion, Coordinate calculations, Built-in PLC, etc	
Power supply	Single phase AC200V~240V 50/60Hz 4.4kVA	
Outer dimensions and mass	420W×230H×298D(mm),17kg	
PC software(option)	TSPC:Program editor,Teaching,Remote operation,etc	
Options	I/O extension, I/O cables, Field Network(CC-Link,DeviceNet,Profibus)*4	
External Memory	USB memory	

*4:Ethernet is a registered trademark of XEROX Corp. in the U.S.A.
CC-Link is a registered trademark of CC-Link Partner Association.
DeviceNet is a registered trademark of ODVA.
Profibus is a registered trademark of Profibus User Organization.

TEACH PENDANT(OPTION)

TH850A External view

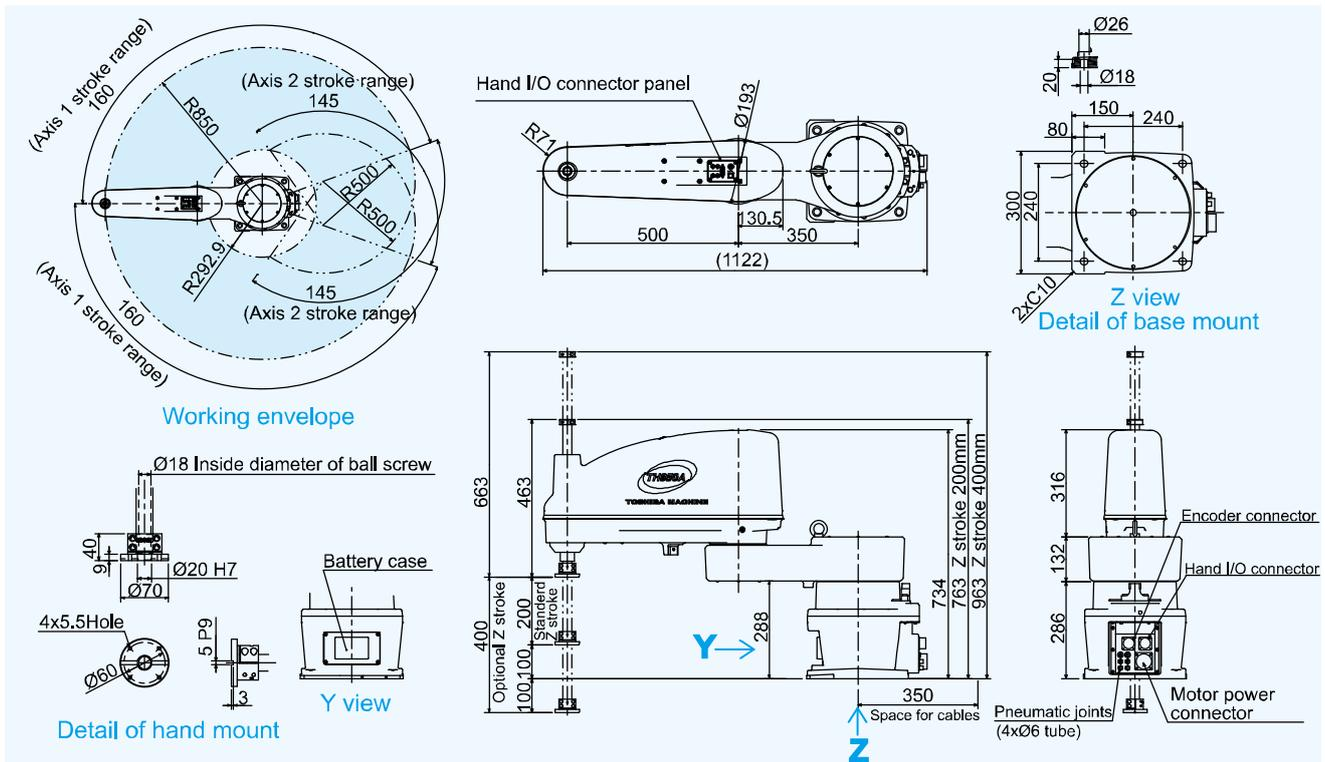

TS3100 External view

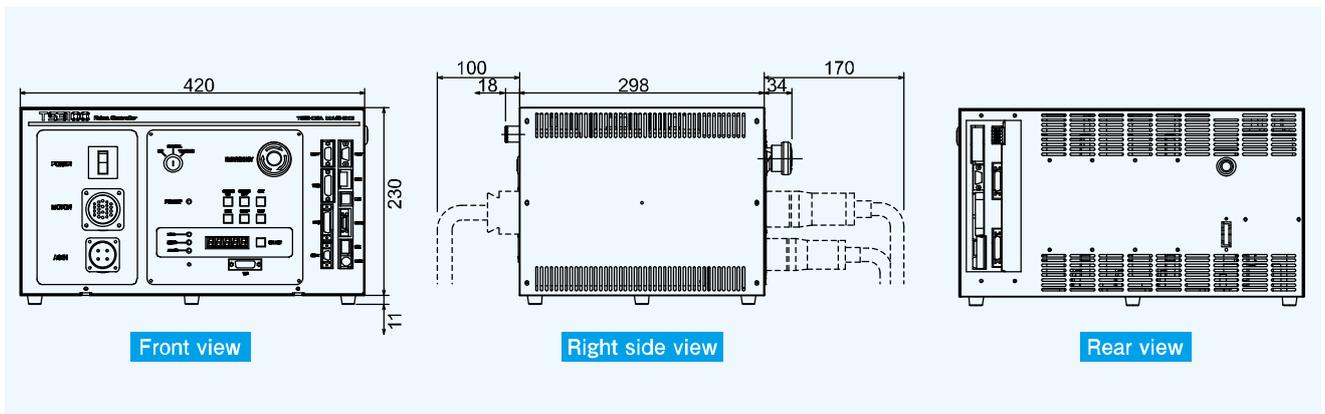

TOSHIBA MACHINE CO.,LTD. HEAD OFFICE
 Control Systems Sales Department, Control Systems Division
 2068-3, Ooka, Numazu-shi, Shizuoka-ken 410-8510, Japan
 TEL:[81](0)55-926-5032 FAX:[81](0)55-925-6527

TOSHIBA MACHINE CO.,AMERICA.
 755 Greenleaf Avenue, EIK Grove Village, IL 60007, U.S.A.
 TEL:[1]-847-593-1616 FAX:[1]-847-593-0897

TM ROBOTICS (EUROPE) LTD.
 Unit 2, Bridge Gate Center, Martinfield,
 Welwyn Garden City, Herts, AL7 1JG,UK
 TEL [44](0)1707-290370 FAX [44](0)1707-376662

URL:http://www.toshiba-machine.co.jp/english/product/sr_e/index.html
<http://www.toshiba-machine.com>
<http://www.tmrobotics.co.uk>



Before operating the industrial robot, read through and completely understand the instruction manuals.

■ The contents included in this catalog are subject to change without prior notice to reflect improvements.